

The home of the turntable

THE VINYL **ENGINE**®

For more turntable manuals and setup information
please visit www.vinylengine.com

Dual 1209

English



Hi-Fi automatic turntable

Operating instructions

Dual Gebrüder Steidinger · 7742 St. Georgen/Schwarzwald

D 773 217 392 20/570
Druck: C. Revellio KG, Villingen
Printed in Germany



Dual 1209

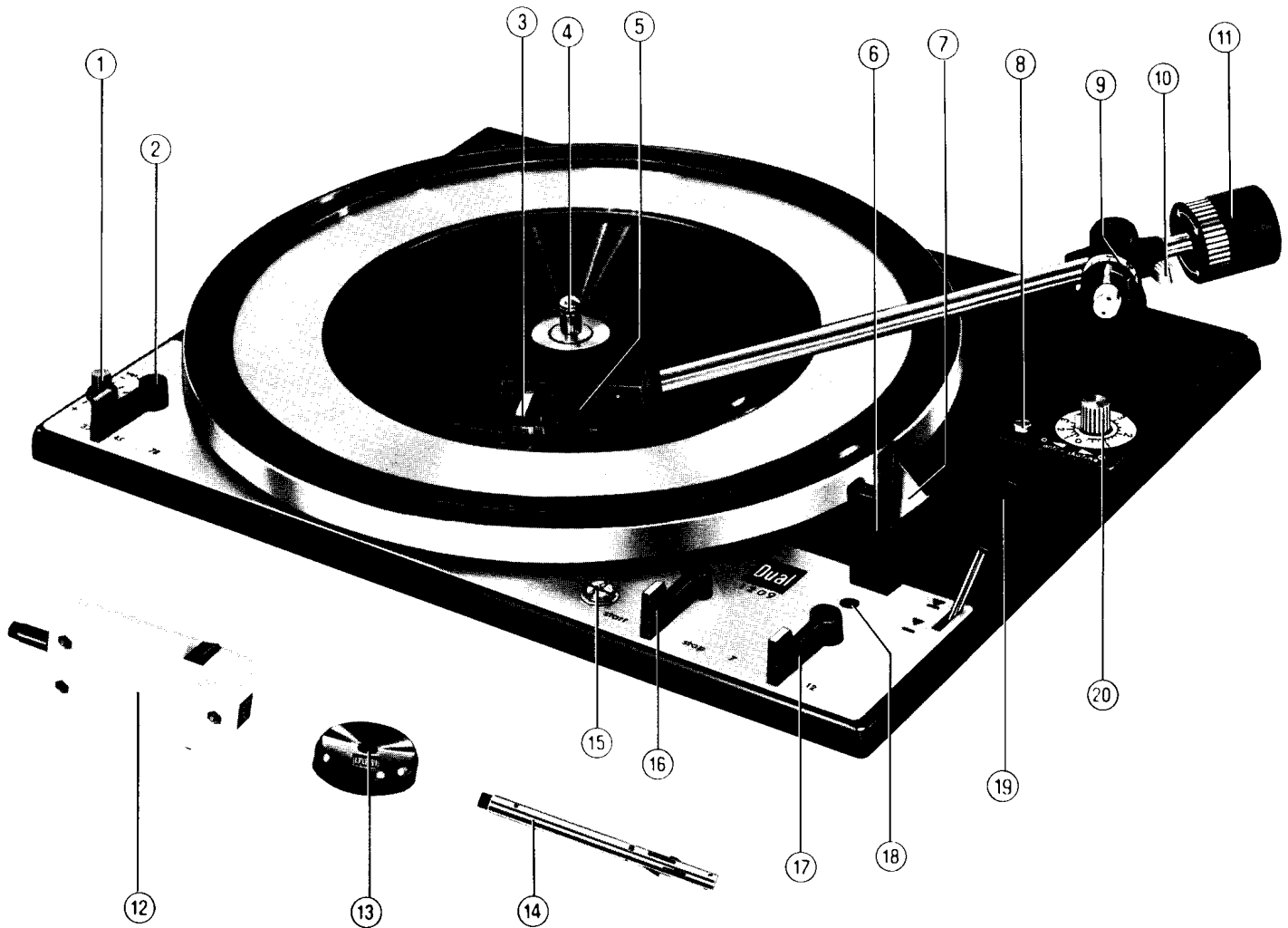

Dear record-lover: Please read these instructions carefully before you set up and operate your new automatic turntable. By doing so, you will avoid faulty operation or possible damage due to mistakes in installation. Move page 2 outward.

Unpacking

See the separate unpacking instructions. This instruction applies only if you have bought the Dual 1209 as a separately packed component. Install the platter by lowering it carefully and slowly onto the shaft. An oil-soaked felt washer will be pushed out as you lower the turntable platter, thus oiling the shaft. It can then be discarded.

If your 1209 does not have a cartridge installed, you will find installation instructions on page 10. With the tonearm locked in place, install the counterbalance at the rear of the tonearm. You will find further instructions for balancing the tonearm and setting stylus force on pages 10 and 11 of these instructions. For the correct stylus force, which depends on the make and model of cartridge, follow the instructions provided with the cartridge.

Installation

The installation instruction is only important if the phonograph is bought without base.

If your system requires a preamplifier, make the necessary connections to the Dual 1209. The following instructions are exceedingly simple:

Press the chassis mounting screws toward the edge of the chassis with your thumbs and set the chassis down on the base cut-out so that the three spring cups slip into their holes. Then turn the mounting screws clockwise. The chassis is now spring-mounted.

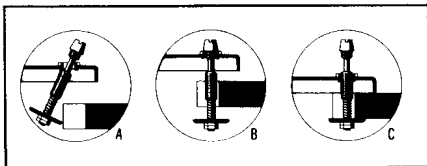

Fig. 1

To secure the 1209 for transport, unscrew the mounting screws, pull them up, then turn them further until the chassis is secured tightly to the mounting board. To prepare the 1209 for use again, turn the two screws clockwise until they slide down about 3/4", then continue to turn in the same direction until they are tight.

Note: After initial installation and after every transport, allow the automatic mechanism to adjust itself by operating the 1209 through one change cycle with the tonearm locked on its rest (move the operating lever to "start").

Power-line connections

For units already installed in console or compact systems, see the instructions for the system.

The 1209 can be used with 50 or 60 Hz alternating current, at 110 or 220 volts. It is normally pre-set for 220 volts, 50 Hz.

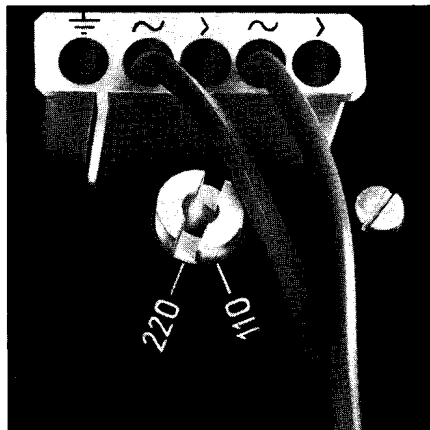

Fig. 2

The voltage for which the 1209 has been pre-set can be read on the voltage selector. The frequency will be found on the nameplate. Both can be found on the underside of the chassis.

In units without a voltage selector, the correct operating voltage must be set by inserting the motor power cable into the appropriate terminals according to the drawing in the power switch cover.

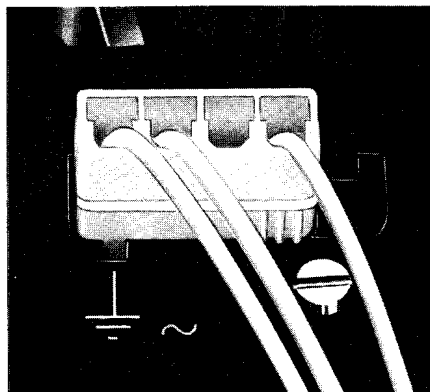

Fig. 3

The power switch is designed so that pre-amplifiers or power amplifiers can be switched on or off automatically as the 1209 is turned on or off.

The load on the power switch must not exceed 400 VA (Volt-amperes). It is generally used only with all-transistor amplifiers, which have no warm-up delay.

The connection is made to contacts provided on the plug portion of the power switch.

In this case, the line cord is to be fitted with AMP plugs as follows:

- B. No. 213 982; AMP-No. 160 565/1 (Fig. 2) for 5-pole power supply plug
- B. No. 209 458; AMP-No. 42859/1 (Fig. 3) for 4-pole power supply plug

Connection to amplifier

For units already installed in systems, consult the instructions for the system.

The 1209 can be fitted with DIN 41 524 miniature connectors (Fig. 4) or with phono (RCA) plugs (Fig. 5).

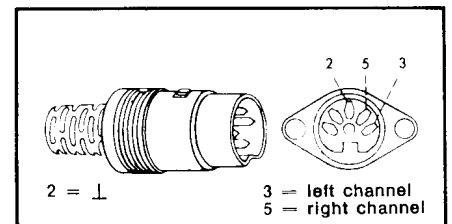

Fig. 4

If your amplifier is fitted with a different type of connector, use suitable adapters, available from audio dealers.

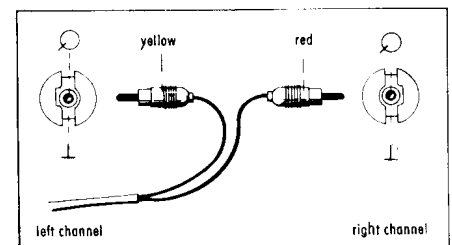

Fig. 5

If the unit is to be connected to a power-transformerless ("ac-dc") radio, amplifier or other equipment, a suitable ground connection must be made to prevent a possible shock hazard. A contact is available for this purpose on the power connector (Figs. 2 and 3).

Operating Instructions

- ① Pitch-control knob
- ② Speed selector
- ③ Tonearm lift and lock
- ④ Rotating single-play spindle
- ⑤ Cartridge holder
- ⑥ Tonearm rest
- ⑦ Tonearm lock
- ⑧ Tonearm cue-control height adjustment
- ⑨ Stylus force adjustment
- ⑩ Counterbalance lock-knob
- ⑪ Tonearm counterbalance
- ⑫ Multiple-play spindle for large-hole records
- ⑬ Adapter for large-hole records
- ⑭ Multiple-play spindle
- ⑮ Chassis hold-down screws (for transport)
- ⑯ Operating switch
- ⑰ Record size selector
- ⑱ Tonearm set-down adjustment
- ⑲ Cue-control
- ⑳ Anti-skating force adjustment

Operating the 1209 as a single-play turntable

Insert the short, single-play spindle (and, for 45 rpm records, the center-hole adapter), then place the desired record on the platter.



Fig. 6

Select the appropriate turntable speed ②, set the record size selector to 7", 10" or 12", depending on the size of the record you want to play, and unlock the tonearm (Fig. 7).

Now the 1209 is ready to play.

The smoothly functioning operating controls select the correct function for automatic single-play or record-changing operation.

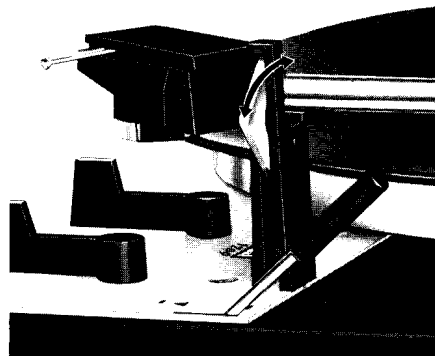

Fig. 7

1. Automatic start.

Push the operating switch to „start“. The motor will start, the tonearm will rise, move to the record, then descend onto the record. The slow descent rate of the cue-control functions automatically.

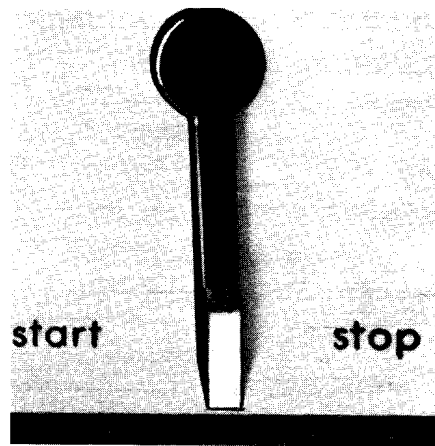

Fig. 8

2. Automatic start with cue-control.

First move the cue-control lever to ∇ , then push the operating switch to "start". The tonearm will descend very slowly and land on the record without jarring in the slightest, controlled by the silicone-damping of the cue-control system.

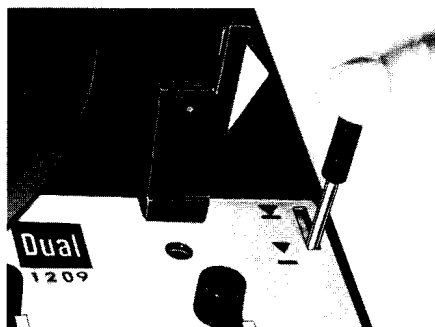

Fig. 9

3. Manual start

Place the tonearm on the record by hand. (As you move the tonearm from the rest post toward the record, the platter will begin to rotate).

4. Manual start with cue-control

- a) Move the cue-control lever to position ∇ .
- b) Move the tonearm by hand over the desired spot on the record.
- c) Lightly tap the lever back to ∇ . (The tonearm will descend).

5. To repeat a record

Push the operating switch to "start".

6. To interrupt play

Move the cue-control lever to ∇ .

7. To resume play where it was interrupted

Move the cue-control lever to ∇ . (A light tap will do). The tonearm will descend and repeat a few grooves.

8. To stop

Move the operating switch to "stop". The tonearm will return to its rest and the motor will shut off.

Note: After a single record has played, or after the last record in a stack has played, the tonearm will return automatically to its rest and the motor will shut off. It is advisable then to lock the tonearm on its rest (Fig. 7).

Automatic record changing

Insert either the conventional changer (long) spindle or the special one for large-hole, 45 rpm records*, so that the key slips into the corresponding slot in the shaft. Lock the spindle in place by pressing down on it as you turn it to the right, until it stops.



Fig. 10

You can stack up six records of the same size and speed.

When you move the operating switch to "start", the first record will drop and the tonearm will lift, move to the record, then descend. If you wish to reject a record that is playing and move on to the next, move the operating switch once again to "start".

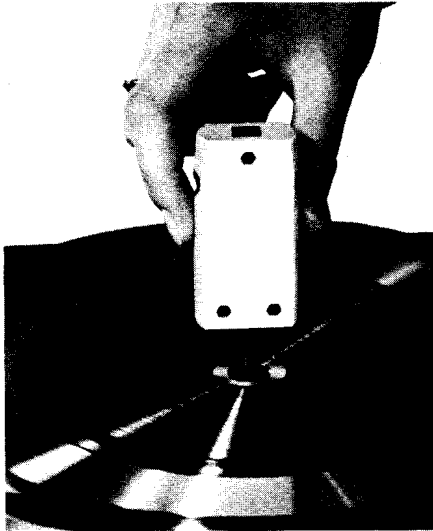

Fig. 11

Playing without interruption

Once the record has been laid down on the platter, insert the puck through the multiple-play spindle. It is recommended to place a 45 rpm record on top of the puck for added weight. The record will then play continuously without interruption.

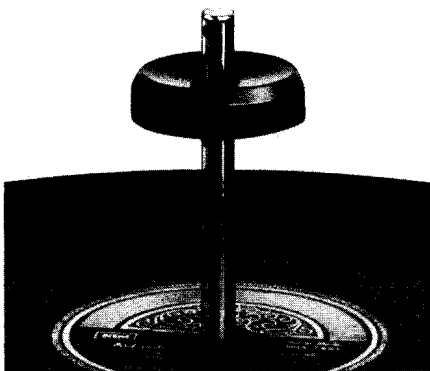

Fig. 12

Note: Records that have been played can be lifted back up the spindle for repeat plays, or removed altogether. There is no need to remove the spindle in either case.

* The 45 rpm record spindle AS 12 is available from audio dealers as an accessory.

Cartridge (pick up)

The following instructions apply only if your 1209 was purchased without a cartridge installed, or if you wish to replace the cartridge supplied with one of your own choosing.

The 1209 will accept any cartridge that weighs from 1 to 12 grams and has standard 1/2" mounting centers.



Fig. 13

1. To install a cartridge, remove the cartridge holder from the tonearm by pressing the lift toward the rear. Hold the cartridge holder or it will fall out once unlocked.
2. Fasten the cartridge in the cartridge holder. Be sure that it is located correctly. The accompanying screws, spacers, nuts and the mounting gauge are supplied to help you do the job right.

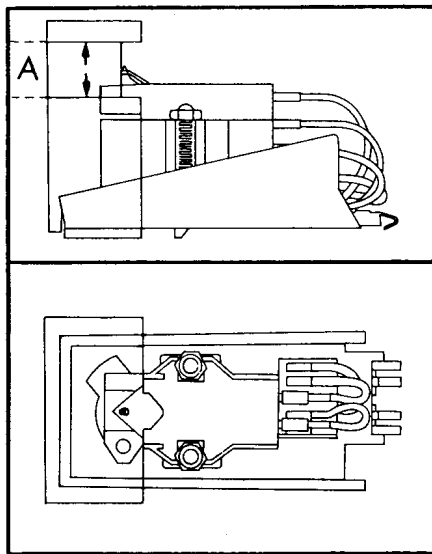

Fig. 14

3. The cartridge is correctly mounted when the notch in the mounting gauge encloses the stylus tip, and when the stylus tip, viewed from the side, is within the area (A) (Fig. 14).
4. The connections on the cartridge holder are marked and the wire leads are color-coded (Fig. 15). Connect the leads with the appropriate terminal pins on the cartridge.

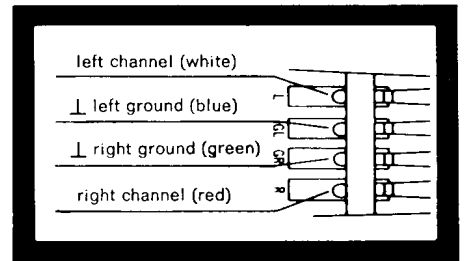

Fig. 15

5. Re-insert the cartridge holder in the tonearm head from underneath, and secure it by moving the tonearm lift forward.

Balancing the tonearm

The tonearm is balanced, first roughly by sliding the counterbalance, and then finely by rotating the weight.

1. Set the stylus force dial to zero.
2. Unlock the tonearm, and lift off the rest.
3. If the tonearm does not come to rest perfectly horizontal, loosen set-screw (F) and slide the counterbalance (with its shaft) until you achieve an approximate balance. Then tighten the set-screw.

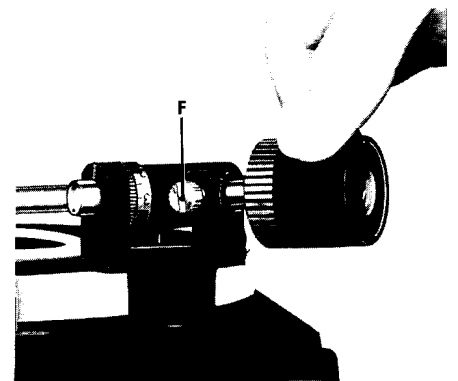

Fig. 16

4. You can now get an exact balance by turning the counterbalance. The tonearm is precisely balanced when edge "A" of the tonearm head and edge "B" of the tonearm rest are at equal height (Fig. 17) or when the tonearm returns by itself to a horizontal position after the chassis is tapped.

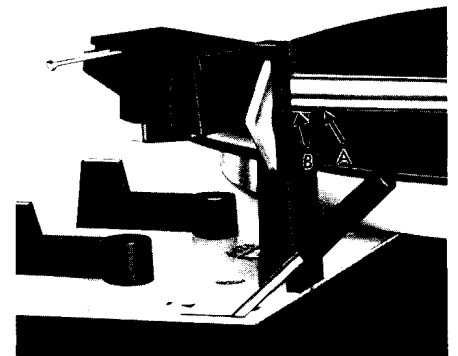

Fig. 17

Precise balance is especially important with cartridges that require a low stylus force. The balancing operation need be done only once, unless you install a different cartridge.

During the balancing of the tonearm the operating switch must be in its neutral position, so that the tonearm is disengaged from the automatic mechanism. To be sure, lock the tonearm on the rest post, then rotate the turntable platter by hand, clockwise, until the operating lever returns to its neutral position.

Setting stylus force

Once the tonearm is balanced, set the stylus force by turning the stylus force dial. The force is continuously adjustable from zero to 5.5 grams with an accuracy of ± 0.1 gram. The 1209 will function properly with as little as 0.5 gram stylus force.



Fig. 18

Every cartridge has an optimum tracking force, which provides the best reproduction. For the best figure for your cartridge, consult the information provided with it.

For factory-installed cartridges, you will find all necessary details in a leaflet that accompanies these instructions.

Too low a stylus force produces distortion in loud recorded passages. Too high a stylus force can damage the stylus and record.

Anti-skating

The skating-force compensation adjustment knob on the chassis makes it possible to adjust anti-skating force while a record is playing – important when going from a dry record to a moistened one.

For the two types of stylus in frequent use today there are two different adjustments scales:

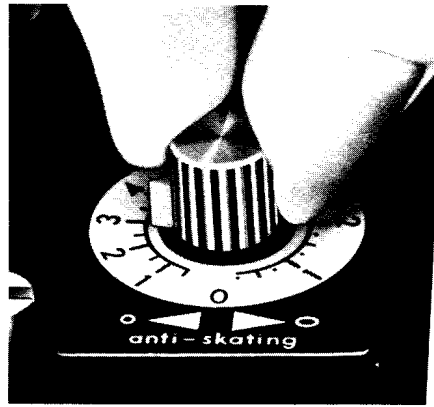

Fig. 19

Red: for (conical) styli with 15 micron radius according to DIN 45 500

Black: for (elliptical) styli with radii of 5 to 6 microns by 18 to 22 microns.

In either case, turn the adjustment knob to the number that corresponds to the stylus force being used. Thus, if you have set the stylus force to 1 gram, set the anti-skating knob to "1" also (on the appropriate scale for the type of stylus you have).

In case of stylus tips with radii other than those given above, you can select the correct anti-skating setting from the table below.

Stylus force

Anti-skating setting for styli with various tip radii in microns.

Tracking force "p"	Anti-skating compensation for stylus radii in microns			
	9	11	13	15
0,5	0,65	0,60	0,55	0,5
1,0	1,15	1,10	1,05	1,0
1,5	1,75	1,60	1,55	1,5
2,0	2,35	2,15	2,05	2,0
2,5	2,85	2,65	2,55	2,5
3,0	3,40	3,15	3,05	3,0
3,5	3,95	3,70	3,60	3,5
4,0	4,60	4,20	4,10	4,0
4,5	5,50	4,70	4,60	4,5
5,0	—	5,25	5,10	5,0

Tracking force "p"	Anti-skating compensation for stylus radii in microns		
	17	19	elliptical 5-6x18-22
0,5	0,45	0,40	0,5
1,0	0,95	0,90	1,0
1,5	1,45	1,40	1,5
2,0	1,95	1,90	2,0
2,5	2,45	2,40	2,5
3,0	2,95	2,90	3,0
3,5	3,45	3,40	
4,0	3,90	3,85	
4,5	4,40	4,35	
5,0	4,90	4,80	

Note: If you play a moistened record, skating force is reduced by approximately 10%. Therefore reduce the given value of skating compensation by about 10%.

Skating force is especially troublesome in stereo records. The resulting inward pull on the tonearm results in a higher pressure against the (inner) groove wall than against the (outer) wall.

To compensate for this skating force and eliminate its effects, a very accurate counterforce – accurate in both magnitude and direction – must be applied to the tonearm.

The anti-skating system of the 1209 fulfills this requirement perfectly.

Cue-control

Your player is equipped with a precise, jolt-free, silicone-damped tonearm lifting device. With this cue-control, the tonearm can be placed over any spot on a record, then lowered more gently than possible by hand. The rate of descent is independent of temperature.

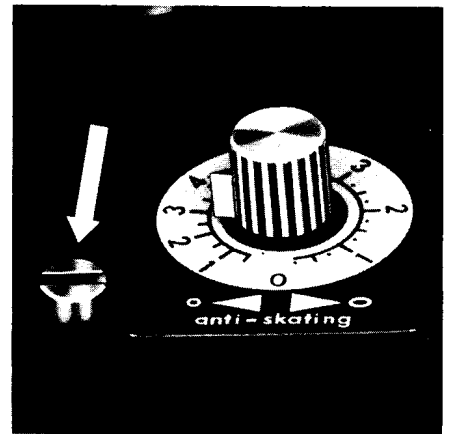

Fig. 20

Its operating lever has two positions: playing position ∇ lift position ∇ , in which the tonearm is lifted off the record surface. A light tap backwards on the lever starts the tonearm descending. The height of the stylus above the record in the ∇ position can be adjusted from zero to about 6 mm ($\frac{1}{4}$ ") with screw $\textcircled{3}$.

Pitch-Control

Each of the three standard speeds (33 $\frac{1}{3}$, 45 and 78 rpm) can be varied about 6% (approximately one musical semitone). The speed can be checked with the stroboscopic disc on the turntable platter. When the disc is illuminated by a light (preferably fluorescent) powered from alternating household current, the ring of

lines corresponding to the chosen speed will appear to stand still when the turntable is rotating at the correct speed. Pitch is varied by using the pitch-control knob ①.



Fig. 21

Adapting for other power frequency

To adapt the unit for use at a different power-line frequency is accomplished by changing the motor pulley (A), which is secured to the motor shaft by a screw and can be reached by removing the turntable platter.

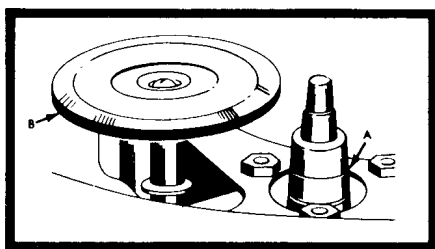

Fig. 22

Caution: Handle the motor pulley carefully. A bent pulley causes rumble. Stock numbers for motor pulleys: For 60 Hz, 218 274, for 50 Hz, 218 273.

Removing the turntable platter

To remove and replace the spring-clip that secures the turntable platter, use the accessory cone-shaped piece provided for the purpose. (Fig. 23 A, removing the spring-clip); Fig. 23 B, replacing the spring-clip)

Important! To avoid possible slippage between idler, motor pulley and platter, do not touch any of the running surfaces with your fingers.

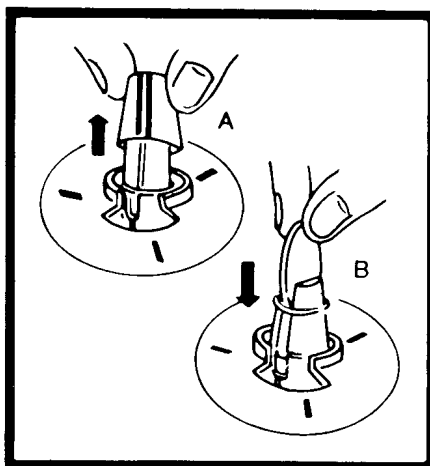

Fig. 23

Adjusting tonearm set-down position

With automatic start, the stylus descends automatically into the outer groove of the record. It is possible, due to peculiarities in the mounting of a cartridge, that the stylus may land too far in or too far out on the record.

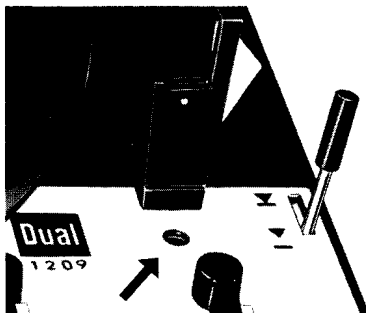

Fig. 24

In that case, set the record size selector for a 12" record (30 cm). Through the hole next to the tonearm rest, you will see an adjustment screw ⑩. If the stylus lands too far into the record, turn the screw very slightly to the left; if it lands too close to the edge, turn it slightly to the right.

Service

All parts that require lubrication are liberally coated with oil. Under normal conditions, your Dual will function perfectly for years. Do not oil any parts; special oils must be used. Should your Dual ever require service, either take it to your dealer or ask him for the address of the nearest authorized Dual service agency. Be sure that original Dual replacement parts only are used. Always ship your Dual in its original packing.

Technical specifications

Power supply:

alternating, 50 or 60 cycle changeable by changing motor pulley

Power supply voltage:

110/117 and 220 V switchable

Drive:

synchronous hi-torque pole motor with radial-elastic suspension

Power consumption:

10 watts approx.

Current drain:

64 ma approx. at 220 V, 50 cycle
115 ma approx. at 117 V, 60 cycle

Turntable platter:

non-magnetic, 10³/₈", weighing 4 lbs. dynamically balances

Turntable speeds:

33¹/₃, 45 and 78 r.p.m.

Pitch control variation:

adjustment range of approx. 1 semitone (6%) at all three turntable speeds

Speed accuracy deviation:

< ± 0,09% in accordance to DIN 45 507

Rumble:

> 42 dB below signal level in accordance to DIN 45 500

Weighted rumble:

> 57 dB below signal level in accordance to DIN 45 500

Tonearm:

torsionally rigid, all metal design with vertical needle bearings, horizontal 2-layer precision ball bearings in hardened and polished races.

Maximum tracking error:

< 1° 45'

Tonearm bearing frictions:

(referred to stylus tip)
vertical: less than 0,01 gram
horizontal: less than 0,04 gram

Cartridge holder:

removable, suitable for acceptance of cartridges having 1/2" mounting and possessing a weight of 1-12 grams.

Weight:

10.8 lbs. less packing

Dimensions:

12³/₈" x 10¹/₄"

Mounting cutouts:

see installation instructions